

24V C.C. - D.C.

VA15-BP70/LL-51A
VA15-BP70/LL-51S

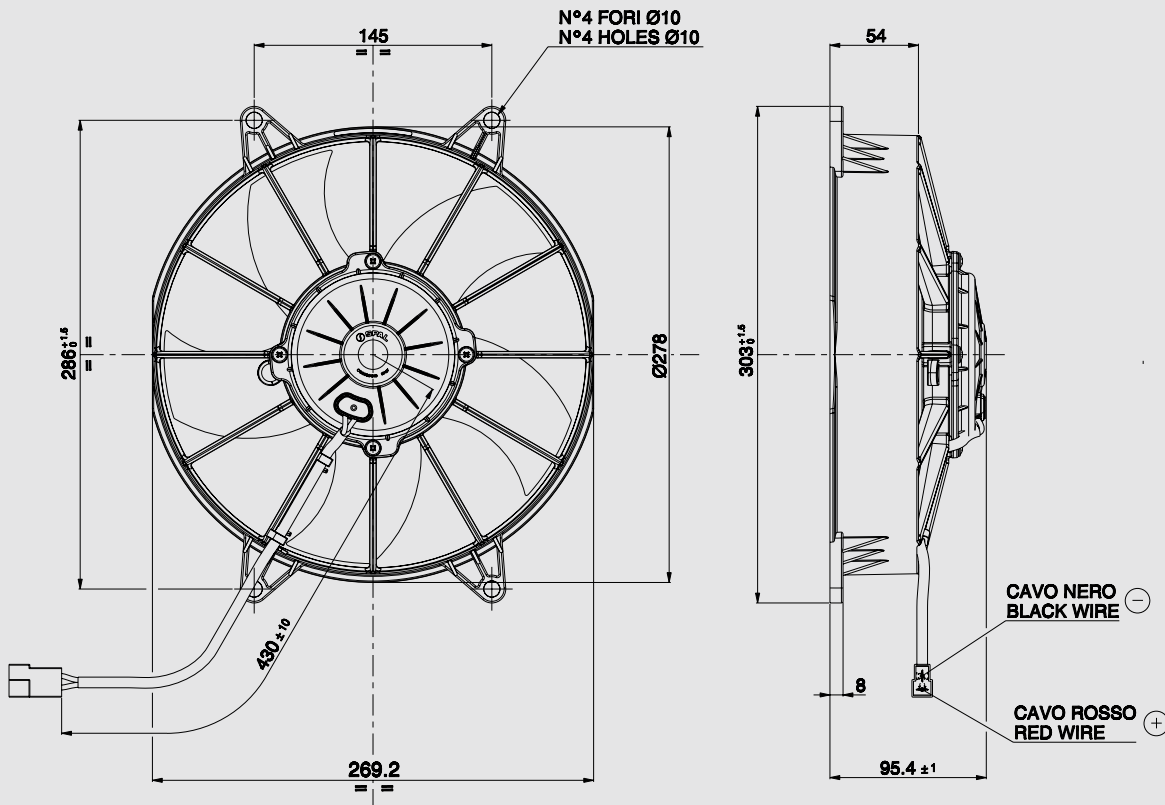

AMP connector Code 180908
AMP terminal Code 42098-2
Suggested mounting torque: 3(+1/-0) Nm with screw M8
Weight 2.24 Kg. approx.

Connettore AMP Cod. 180908
Terminali AMP Cod. 42098-2
Coppia di serraggio consigliata: 3(+1/-0) Nm con vite M8
Peso 2,24 Kg. circa

Ø 255 mm

Ø 10"

suction / aspirante

blowing / soffiante

PRODUCT FEATURES
CARATTERISTICHE PRODOTTO

Static pressure Pressione statica mm H ₂ O	suction / aspirante			blowing / soffiante			Static pressure Pressione statica in H ₂ O
	Airflow Portata m ³ /h	Current input Corrente assorbita A	Airflow Portata CFM	Airflow Portata m ³ /h	Current input Corrente assorbita A	Airflow Portata CFM	
0	1910	5,6	1127	1790	5,2	1056	0
5	1720	5,8	1015	1620	5,5	956	0,2
10	1450	6,0	856	1440	5,8	850	0,4
15	1100	6,0	649	1200	6,1	708	0,6
20	710	6,0	419	920	6,3	543	0,8
25	530	6,3	313	600	6,3	354	1
30	390	6,4	230	300	6,4	177	1,2
35	320	6,6	189	220	6,4	130	1,4
40	170	7,1	100	0	6,7	0	1,6
45	0	7,9	0				1,8

Waterproof motor, IP 68 Motore chiuso, IP 68	✓
Low noise / Bassa rumorosità	✓
Long life / Lunga durata	✓
VLL version* / Versione VLL*	✓
Waterproof connector Connettori a tenuta stagna	✓

* for OEM applications only.
* per applicazioni OEM

✓ = Standard feature
Caratteristiche standard
✓ = Available upon request
Disponibile su richiesta

Test voltage 26 V. D.C. - Tensione di prova 26 V. c.c.